

## CLASSIC 1 group



---

### Ref602645 (UCLASSIC1\_110VUL)

Traditional espresso maker, 1 group, 6.3 liter boiler, 4 programmable dosing program, manual steam & water, automatic cleaning cycle, stainless steel body

#### General Features

Traditional single group espresso maker with large steam boiler. Elegant lines and reliable technologies appreciated by coffee professionals, the CLASSIC model is made more attractive by its quality/ price ratio. Designed for rugged commercial application, the CLASSIC is the perfect traditional espresso machine to ensure an excellent quality espresso result, consistency and high performance during rush period.

## CLASSIC 1 group

### Main Features

- Maestro brew group: directly to boiler group heads are mounted for shot temperature stability.
- Large cup warming capacity: integrated cup warmer on the top of the machines.
- 4 programmable volume keys per group + Semi-automatic key for each group for manual control.
- Automatic cleaning program.
- The CLASSIC Elegant lines and reliable technologies appreciated by coffee professionals, the CLASSIC model is made more attractive by its quality/ price ratio. The CLASSIC is the perfect traditional espresso machine to ensure an excellent quality espresso result, and consistency even during the busiest periods of the day.
- Heavy duty components and welded construction, a direct mounted boiler group head for thermal stability and reliable extraction, easy access to components for uncomplicated servicability, and unlimited steam.

### Construction

- Built-in cup warmer.

### Included Accessories

#### Optional Accessories

- KIT OF RAISED 3" FEET PNC 871041

# CLASSIC 1 group

## Electric

Supply voltage:

602645  
(UCLASSIC1\_110VUL) 110 V/1 ph/60 Hz

Electrical power, max: 1.7 kW

Plug type:

## Water:

Cold water temperature  
(min/max): 5 / 60 °C

## Key Information:

External dimensions, Width:	13 1/2" (343 mm)
External dimensions, Depth:	22 3/8" (568 mm)
External dimensions, Height:	22 13/16" (580 mm)
External dimensions, Weight:	90 lbs (41 kg)
Net weight:	90 lbs (41 kg)
Shipping width:	19 11/16" (500 mm)
Shipping depth:	29 1/2" (750 mm)
Shipping height:	33 1/16" (840 mm)
Shipping weight:	112 lbs (51 kg)
Shipping volume:	0.3 m <sup>3</sup>

## Certifications



The company reserves the right to make modifications to the products without prior notice. All information correct at time of printing.

2024.10.07

Part of  Electrolux  
Professional  
Group

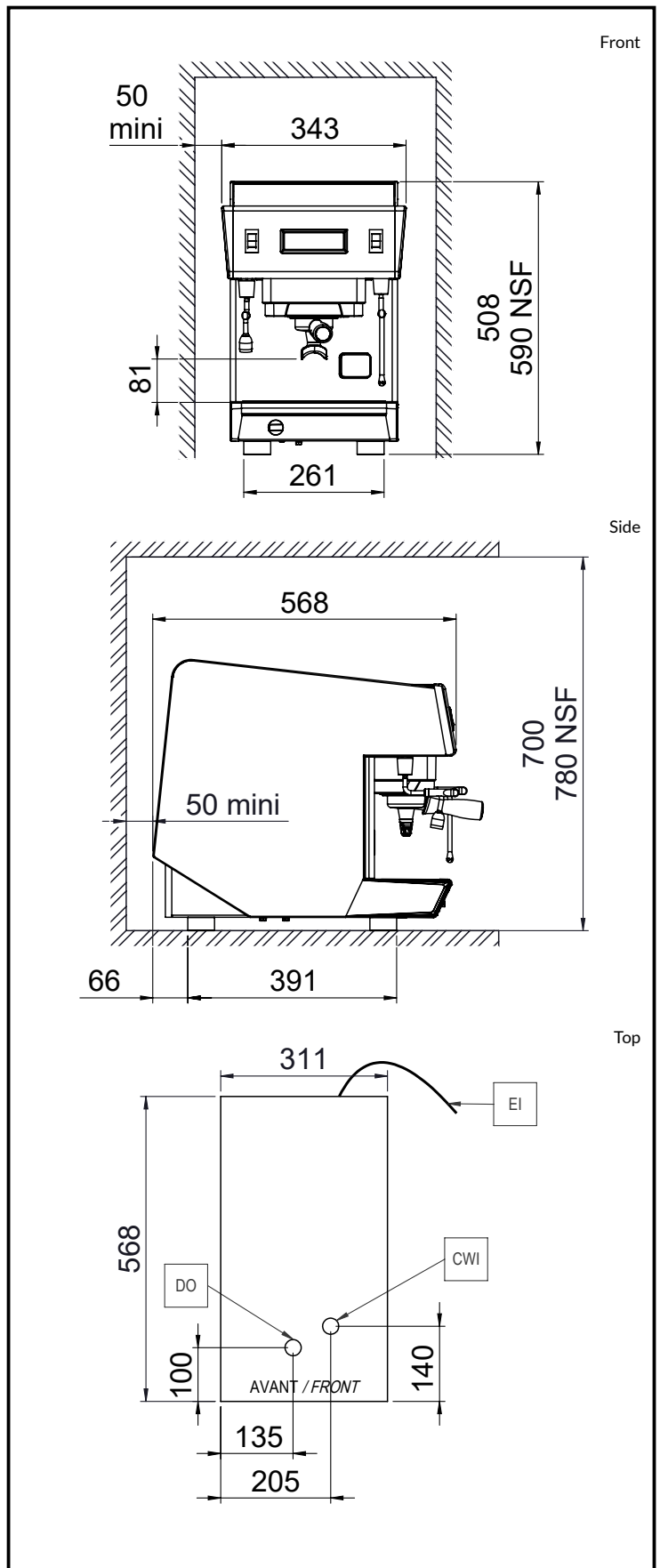

# UNIC